

1 WATER QUALITY PLAN
C-1.0 1" = 20'-0"

WATER QUALITY CALCULATIONS LOT 1:

STORMWATER IMPERVIOUS AREA CALS:

PROPOSED ROOF RESIDENCE=	2,691 sq ft
PROPOSED ROOF FRONT COVERED PORCH=	122 sq ft
PROPOSED ROOF BACK SCREEN PORCH=	180 sq ft
PROPOSED DRIVEWAY / WALKWAY=	578 sq ft
TOTAL=	3,571 sq ft

WATER QUALITY CALCULATIONS LOT 2:

STORMWATER IMPERVIOUS AREA CALS:

PROPOSED ROOF RESIDENCE=	2,691 sq ft
PROPOSED ROOF FRONT COVERED PORCH=	122 sq ft
PROPOSED ROOF BACK SCREEN PORCH=	180 sq ft
PROPOSED DRIVEWAY / WALKWAY=	571 sq ft
TOTAL=	3,564 sq ft

WATER QUALITY NOTES:

- 1) BMP DEVICES TO BE INSTALLED AT THE TIME OF FINAL LANDSCAPING.
- 2) ALL COLLECTED WATER SHALL BE DIRECTED TO THE BMP(S)
- 3) SCHEDULE 20 OR 40 PVC SHALL BE USED, NO FLEXPipe ALLOWED
- 4) POP-UP OVERFLOW DEVICES SHALL DISCHARGE NO CLOSER THAN 10'-0" AND PIPING SHALL HAVE A POSITIVE SLOPE AWAY FROM THE FOUNDATION
- 5) A CLEANOUT AND/OR EMERGENCY BYPASS SHALL BE PROVIDED
- 6) ALL ROOF DRAINAGE SHALL BE TIED INTO CLEAN WATER DRAINAGE SYSTEM

LEGEND

	POWER LINE
	SANITARY SEWER LINE
	CLEAN-OUT
	SANITARY SEWER MANHOLE
	PP POWER POLE
	OVERFLOW WITH POP-UP EMITTER
	DOWNSPOUT
	CATCH BASIN FILTER

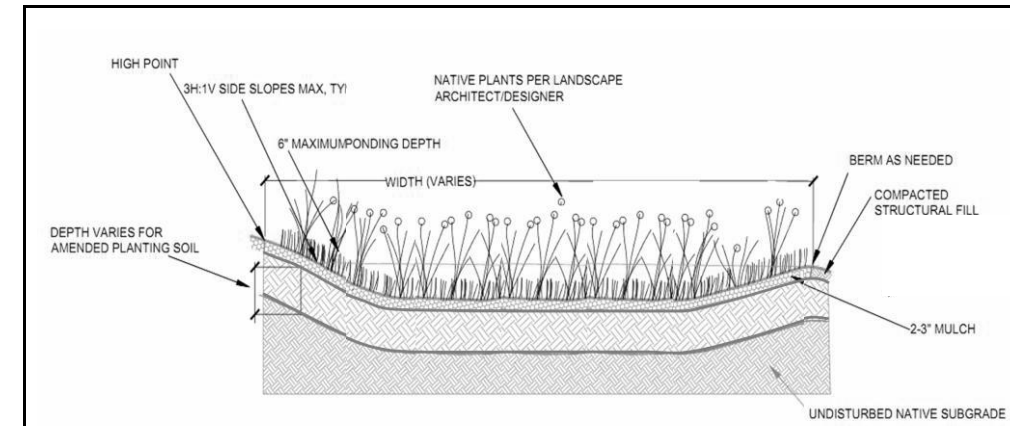

CONSTRUCTION STEPS:

1. Locate rain garden(s) where downspouts or driveway runoff can enter garden flowing away from the home. Locate at least 10 feet from foundations, not within the public right of way, away from utility lines, not over septic fields, and not near a steep bluff edge.
2. Measure the area draining to the planned garden and determine required rain garden surface area from the table on the next page and your planned excavation depth.
3. Optionally, perform infiltration test according to Appendix A. If the rate is less than 0.25 in/hr an underdrain will be necessary. If the rate is more than 0.50 in/hr the size of the garden may be decreased 10% for every 0.50 in/hr infiltration rate increase above 0.50 in/hr.
4. Measure elevations and stake out the garden to the required dimensions insuring positive flow into garden, the overflow elevation allows for six inches of ponding, and the perimeter of the garden is higher than the overflow point. If the garden is on a gentle slope a berm at least two feet wide can be constructed on the downhill side and/or the garden can be dug into the hillside taking greater care for erosion control at the garden inlet(s).
5. Remove turf or other vegetation in the area of the rain garden. Excavate garden being careful not to compact soils in the bottom of the garden. Level bottom of garden as much as possible to maximize infiltration area.
6. Mix compost, topsoil, and some of the excavated subsoil together to make the 'amended soil'. The soil mix should be 1/3 compost, 2/3 native soil (topsoil and subsoil combined).
7. Fill rain garden with the amended soil, leaving the surface eight inches below your highest surrounding surface. Eight inches allows for 6 inches ponding and 2" of mulch. The surface of the rain garden should be as close to level as possible.
8. Build a berm at the downhill edge and sides of the rain garden with the remaining subsoil. The top of the berm needs to be level, and set at the maximum ponding elevation.
9. Plant the rain garden using a selection of plants from elsewhere in this manual.
10. Mulch the surface of the rain garden with two to three inches of non-floating organic mulch. The best choice is finely shredded hardwood mulch. Pine straw is also an option.
11. Water all plants thoroughly. As in any new garden or flower bed, regular watering will likely be needed to establish plants during the first growing season.
12. During construction build the inlet feature as a pipe directly connected to a downspout or use a rock lined swale with a gentle slope. Use of an impermeable liner under the rocks at the end of the swale near the house is recommended to keep water from soaking in at that point. Test the drainage of water from the source to the garden prior to finishing.
13. Create an overflow at least 10 feet from your property edge and insure it is protected from erosion.

NAME/ADDRESS:	RAIN GARDEN SPECIFICATIONS PAGE 1 OF 2
---------------	--

SKETCH LAYOUT
PROVIDE PLAN VIEWS OF RAIN GARDEN AND HOUSE SHOWING DRAINAGE AREA DIRECTED TO RAIN GARDEN AND KEY DIMENSIONS AND OVERFLOW AREA RELATIVE TO PROPERTY LINE.

SEE PLAN FOR
DOWNSPOUT, AREA DRAIN AND
RAIN GARDEN LOCATON

SIZING CALCULATION:

Contributing Drainage Area (square feet)	Depth of Amended Soil (inches)			
	18	24	30	36
100	6.6	5.7	5.1	4.6
500	35	30	25	23
1000	65	60	50	45
2000	135	115	100	90
3000	200	170	150	140
4000	260	230	200	185
5000	330	290	255	230

MEASURE CONTRIBUTING DRAINAGE AREA AND READ AREA FOR GIVEN MEDIA DEPTH.

CONTRIBUTING DRAINAGE AREA= **3,571** SQ FT
DEPTH OF SOIL MEDIA= **18** INCHES
AREA OF RAIN GARDEN= **233** SQ FT PROVIDED=238 sq ft

MAINTENANCE:

1. IRRIGATE VEGETATION AS NEEDED IN FIRST SEASON
2. REMOVE WEEDS
3. REPLACE UNSUCCESSFUL PLANTINGS
4. REPLENISH MULCH
5. REPAIR ERODED AREAS
6. RAKE CLOGGED SURFACE TO RESTORE INFILTRATION
7. MONITOR RAIN GARDEN FOR APPROPRIATE DRAINAGE TIMES IF GARDEN DOES NOT DRAIN AN UNDERDRAIN MAY BE NECESSARY

ATTACH THIS TWO-PAGE SPECIFICATION TO HOUSE PLAN SUBMITTAL	RAIN GARDEN SPECIFICATIONS PAGE 2 OF 2
--	--

SCALE: 1"=20'-0"



227 SUMAC TRL,
WOODSTOCK, GA 30188
404-218-9579
www.vestengineering.com



THIS DRAWING IS AN INSTRUMENT OF THE ENGINEER'S SERVICE FOR USE SOLELY WITH RESPECT TO THE PROJECT SHOWN AND MAY NOT BE DUPLICATED OR USED WITHOUT THE CONSENT OF ENGINEER.

ISSUES & REVISIONS

PROJECT:
Rezoning Plan
Allan Khalife
1540 Whitfield St, Smyrna, GA 30080

CONTENTS:

WATER QUALITY PLAN

DATE:
10-8-19

SHEET No:

C-1.0

OF: SHEETS:

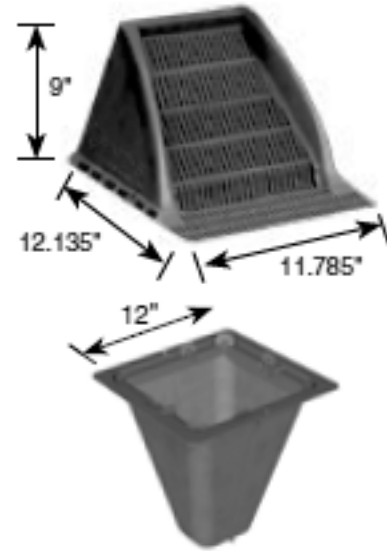

Part No.	Description	Color	Pkg. Qty.	Wt. Ea. (lbs.)	Product Class	Specifications
1200DSG	12" x 12" Downspout Grate	Black	8	n/a	10ND	12" x 12" Downspout Grate. Structural Foam Polyolefin with UV inhibitor.
Receives downspouts from 2" to 6" round or square. Fits all NDS 12" square Catch Basins, Risers and Low-Profile adapters.						

Part No.	Description	Color	Pkg. Qty.	Wt. Ea. (lbs.)	Product Class	Specifications
1200FF	12" Catch Basin Filter	Blue Frame/Black Bag	8	0.10	10ND	Polypropylene Frame Fabric is non-woven geotextile 956 PM/SF.
Compatible with these basins: 1200, 1200NGB, 1203, 1204, 1216, 1217, 1225 NDS Catch Basins & Kits.						

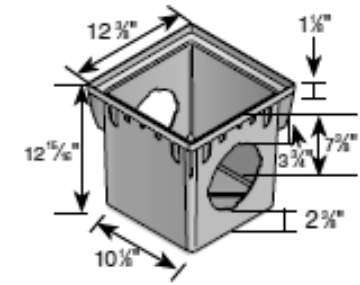

Part No.	Description	Color	Pkg. Qty.	Wt. Ea. (lbs.)	Product Class	Specifications
1200BLKIT	12" x 12" Catch Basin, 2 Open Sides	Black Grate	4	7.59	10ND	12" x 12" Tapered Catch Basin. Polypropylene.
1200GRKIT	12" x 12" Catch Basin, 2 Open Sides	Green Grate	4	7.59	10ND	
1200KITDISP	12" x 12" Catch Basin, 2 Open Sides	Black Grate	8	7.59	10ND	Kits include 2-opening Catch Basin, Grate, 2 Outlets and 1 Plug.
1200GGBLKITWH	12" Basin with Wave Decorative Grate	Black Grate	4	7.59	10ND	
1200GGKITWH	12" Basin with Botanical Decorative Grate	Green Grate	4	7.59	10ND	DISP includes display box.
1200	12" x 12" Catch Basin, 2 Openings	Black	4	4.25	10ND	
1203	12" x 12" Catch Basin, 3 Openings	Black	4	3.75	10ND	
1204	12" x 12" Catch Basin, 4 Openings	Black	4	3.75	10ND	
Requires either #1206, #1242, #1243, #1245, #1266 or #1889 Universal Outlet to connect pipe to basin (see page 33). Bottom cutout can be removed.						

1 CATCH BASIN FILTER DETAIL (TYP.)
C-1.1 N.S.T.

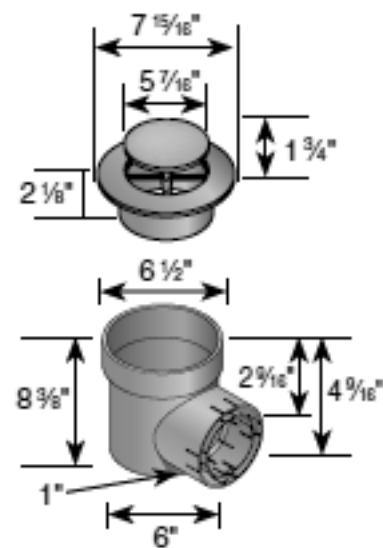

Part No.	Description	Color	Pkg. Qty.	Wt. Ea. (lbs.)	Product Class	Specifications
625	6" Pop-up Emitter with Speed-Basin	Green	8	2.21	10ND	NDS #620 polyolefin spring-loaded Pop-up Drainage Emitter with UV inhibitor and Speed-Basin. 88 GPM. 0.04 psi or 1" of head to raise top.

2 POP-UP DRAINAGE EMITTER DETAIL (TYP.)
C-1.1 N.S.T.

VEST
ENGINEERING INC.

227 SUMAC TRL,
WOODSTOCK, GA 30188
404-218-9579
www.vestengineering.com



THIS DRAWING IS AN INSTRUMENT OF THE ENGINEER'S SERVICE FOR USE SOLELY WITH RESPECT TO THE PROJECT SHOWN AND MAY NOT BE DUPLICATED OR USED WITHOUT THE CONSENT OF ENGINEER.

ISSUES & REVISIONS

PROJECT:
Rezoning Plan
Allan Khalife
1540 Whitfield St, Smyrna, GA 30080

CONTENTS:

WATER QUALITY
DETAILS

DATE:
10-8-19

SHEET No:

C-1.1

OF: SHEETS:

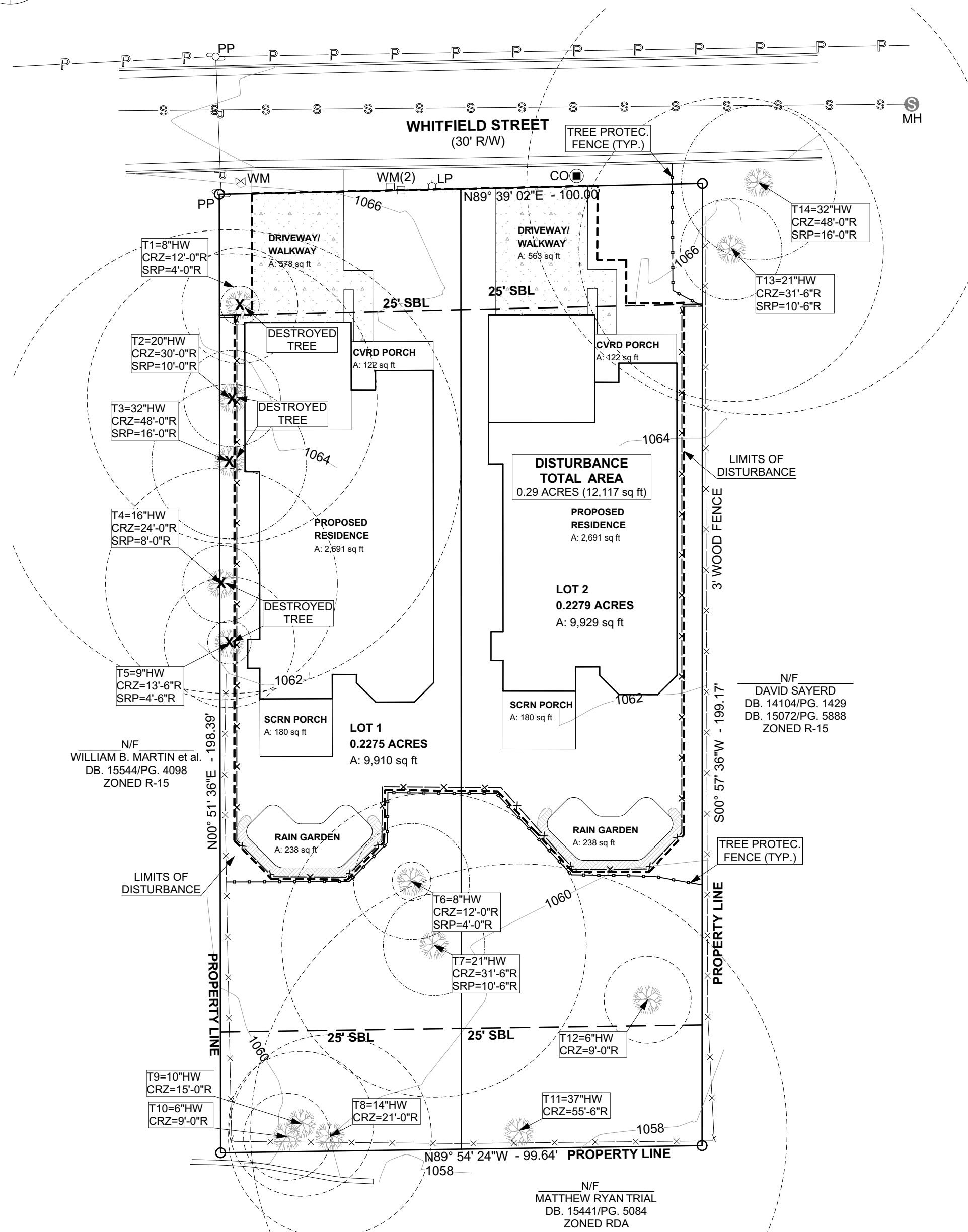
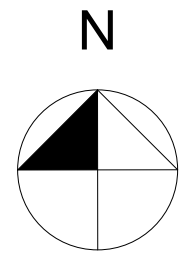

1 TREE PROTECTION PLAN
C-1.2 1"=20'-0"

**LOT 1:
CRITICAL ROOT ZONE CALCULATIONS**

TREE X = TX

- TREE 1 (T1): 8" DBH SOFTWOOD CRZ AREA: $\pi(12')^2=452$ SQ FT
DISTURBED AREA: 203 SQ FT
RATIO OF CRZ IMPACTED: $203/452=0.45$ 45% > 20%
(DESTROYED TREE)
- T2: 20" DBH SOFTWOOD CRZ AREA: $\pi(30')^2=2,827$ SQ FT
DISTURBED AREA: 1,338 SQ FT
RATIO OF CRZ IMPACTED: $1338/2827=0.47$ 47% > 20%
(DESTROYED TREE)
- T3: 32" DBH SOFTWOOD CRZ AREA: $\pi(48')^2=7,238$ SQ FT
DISTURBED AREA: 3,454 SQ FT
RATIO OF CRZ IMPACTED: $3454/7238=0.48$ 48% > 20%
(DESTROYED TREE)
- T4: 16" DBH SOFTWOOD CRZ AREA: $\pi(24')^2=1,809$ SQ FT
DISTURBED AREA: 776 SQ FT
RATIO OF CRZ IMPACTED: $776/1809=0.43$ 43% > 20%
(DESTROYED TREE)
- T5: 9" DBH SOFTWOOD CRZ AREA: $\pi(13.5')^2=572$ SQ FT
DISTURBED AREA: 258 SQ FT
RATIO OF CRZ IMPACTED: $258/572=0.45$ 45% > 20%
(DESTROYED TREE)

- T6: 8" DBH SOFTWOOD CRZ AREA: $\pi(12')^2=452$ SQ FT
DISTURBED AREA: 16 SQ FT
RATIO OF CRZ IMPACTED: $16/452=0.15$ 15% < 20% O.K.
- T7: 21" DBH SOFTWOOD CRZ AREA: $\pi(31.5')^2=3,117$ SQ FT
DISTURBED AREA: 157 SQ FT
RATIO OF CRZ IMPACTED: $157/3117=0.03$ 3% < 20% O.K.
- T8: 14" DBH SOFTWOOD CRZ AREA: $\pi(21')^2=1,385$ SQ FT
DISTURBED AREA: 0 SQ FT
RATIO OF CRZ IMPACTED: NOT IMPACTED
- T9: 10" DBH SOFTWOOD CRZ AREA: $\pi(15')^2=707$ SQ FT
DISTURBED AREA: 0 SQ FT
RATIO OF CRZ IMPACTED: NOT IMPACTED
- T10: 6" DBH SOFTWOOD CRZ AREA: $\pi(9')^2=254$ SQ FT
DISTURBED AREA: 0 SQ FT
RATIO OF CRZ IMPACTED: NOT IMPACTED

**LOT 2:
CRITICAL ROOT ZONE CALCULATIONS**

- T11: 37" DBH SOFTWOOD CRZ AREA: $\pi(55.5')^2=9,677$ SQ FT
DISTURBED AREA: 0 SQ FT
RATIO OF CRZ IMPACTED: NOT IMPACTED
- T12: 6" DBH SOFTWOOD CRZ AREA: $\pi(9')^2=254$ SQ FT
DISTURBED AREA: 0 SQ FT
RATIO OF CRZ IMPACTED: NOT IMPACTED
- T13: 21" DBH SOFTWOOD CRZ AREA: $\pi(31.5')^2=3,117$ SQ FT
DISTURBED AREA: 369 SQ FT
RATIO OF CRZ IMPACTED: $369/3117=0.12$ 12% < 20% O.K.
- T14: 32" DBH SOFTWOOD CRZ AREA: $\pi(48')^2=7,238$ SQ FT
DISTURBED AREA: 676 SQ FT
RATIO OF CRZ IMPACTED: $676/7238=0.09$ 9% < 20% O.K.

DENSITY FACTOR ANALYSIS

SDF = EDF + RDF Where:

SDF (Site Density Factor) = The minimum tree density required to be maintained on a developed site (100 inches per acre).

LOT 1=0.2275 ACRES X 100=22.75" USE SDF=23"
LOT 2=0.2279 ACRES X 100=22.79" USE SDF=23"

EDF (Existing Density Factor) = Density of existing trees to be conserved on a site.

LOT 1=EDF=59" (AFTER LOSS OF TREES)
LOT 2=EDF=43" (AFTER LOSS OF TREES)

LOT 1:
SITE TREE DENSITY REQUIRED=23"<59" = EXISTING TREE DENSITY PROVIDED O.K.

LOT 2:
SITE TREE DENSITY REQUIRED=23"<43" = EXISTING TREE DENSITY PROVIDED O.K.

**LOT 1:
CALCULATION OF EXIST.
DENSITY FACTOR**

DBH	TREES	INCHES
6"	1	6"
8"	1	8"
10"	1	10"
14"	1	14"
21"	1	21"
TOTAL	5	59

**LOT 2:
CALCULATION OF EXIST.
DENSITY FACTOR**

DBH	TREES	INCHES
6"	1	6"
37"	1	37"
TOTAL	2	43

SCALE: 1"=20'-0"

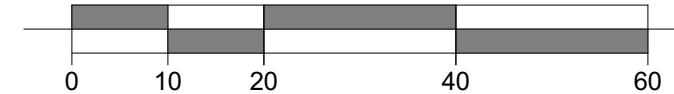

THIS DRAWING IS AN INSTRUMENT OF THE ENGINEER'S SERVICE FOR USE SOLELY WITH RESPECT TO THE PROJECT SHOWN AND MAY NOT BE DUPLICATED OR USED WITHOUT THE CONSENT OF ENGINEER.

ISSUES & REVISIONS

NO.	DESCRIPTION

Rezoning Plan
Allan Khalife
 1540 Whitfield St, Smyrna, GA 30080

PROJECT:

CONTENTS:

TREE PROTECTION PLAN

DATE:
10-8-19

SHEET No:

C-1.2

OF: SHEETS:



THIS DRAWING IS AN INSTRUMENT OF THE ENGINEER'S SERVICE FOR USE SOLELY WITH RESPECT TO THE PROJECT SHOWN AND MAY NOT BE DUPLICATED OR USED WITHOUT THE CONSENT OF ENGINEER.

ISSUES & REVISIONS

PROJECT:
Rezoning Plan
Allan Khalife
1540 Whitfield St, Smyrna, GA 30080

CONTENTS:
TREE PROTECTION DETAILS

DATE:
10-8-19

SHEET No:

C-1.3

OF: SHEETS:

TREE PROTECTION

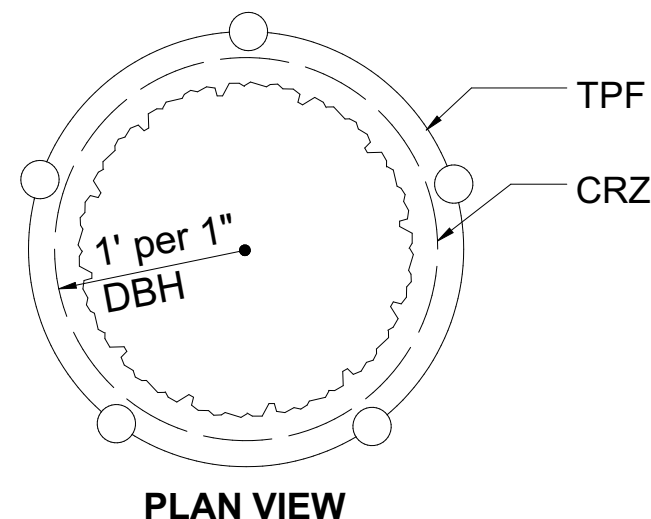

PLAN VIEW

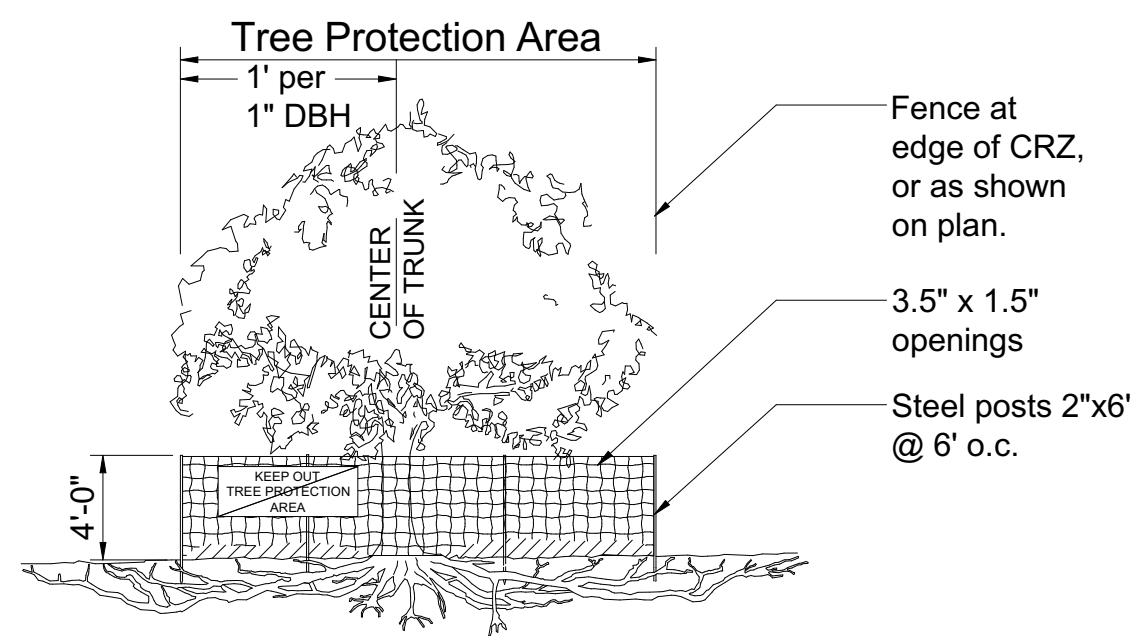

SECTION VIEW

Notes:

1. No construction activity w/in CRZ; including no storing or stacking materials. Under no circumstances should the fence be trenched in.
2. Tree Protection Fence (TPF) shall remain in place and maintained by repair or replacement throughout construction period or until landscape operations dictate adjustment or removal.

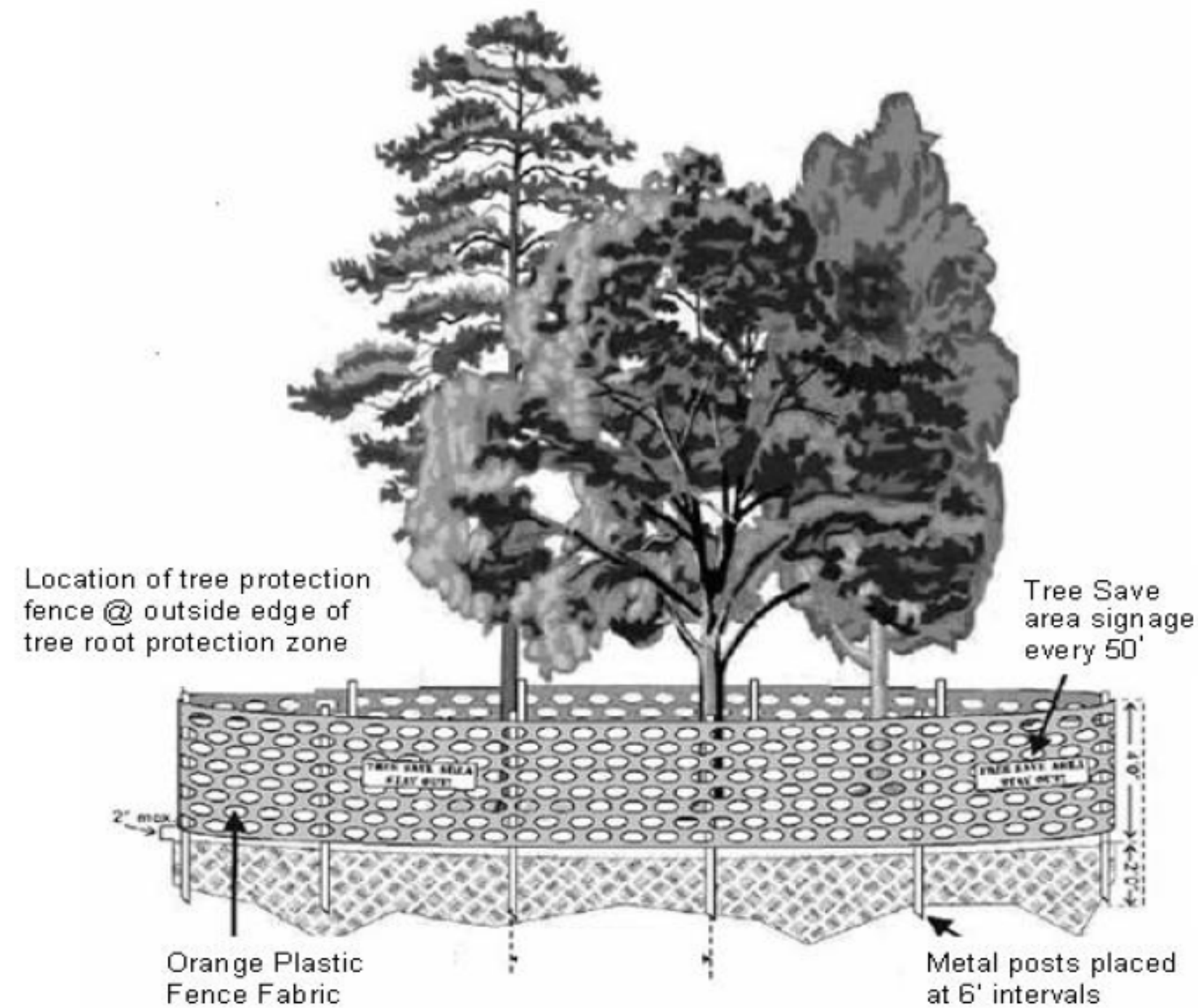

****Specimen tree protection requires orange polyethylene fence be replaced with chain link.*****

TREE PROTECTION FENCING FOR NON-SPECIMENT TREES

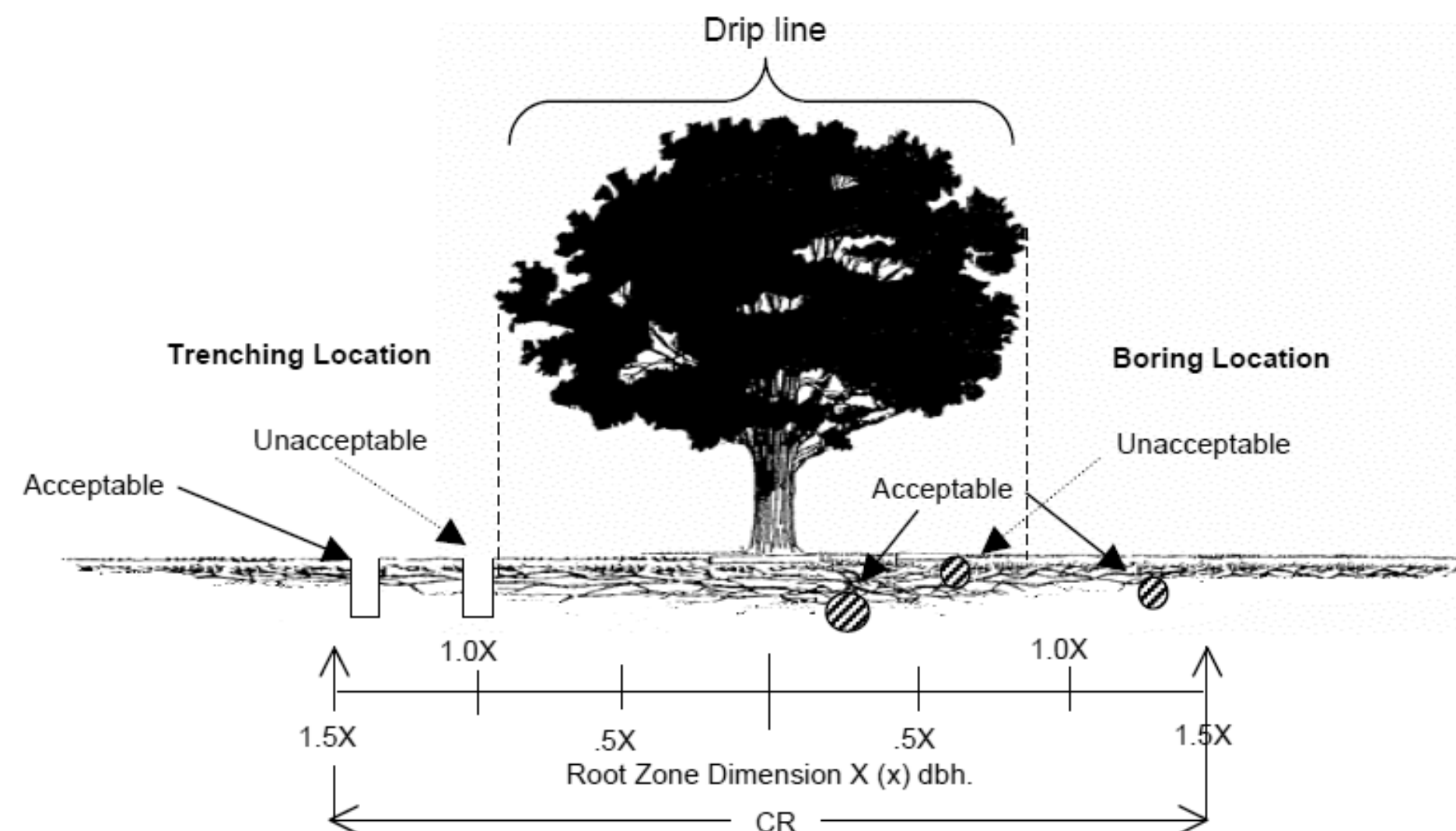

All trenching should be conducted outside the Critical Root Zone (CRZ). When impacts must occur within the CRZ, boring beneath the existing root zone is acceptable – typically 24" – 30" deep. This includes the installation of all utility and irrigation systems.

TUNNELING OR BORING WITH TREE ROOT ZONES